

GiboSmartSolutions

GiboWeld

Gibotech's automated welding solutions GiboWeld Compact are based on known technology and a KUKA platform. The solution is provided as a complete turnkey solution as described on the back and can be easily adapted to customer-specific requirements as needed.



ADVANTAGES

- Compact mobile cell that saves space in the workshop
- Quick start welding tasks with simple simulation and off-line programming with pre-configured simulation modules
- High loading/unloading during the welding process
- The cell may be placed on a lorry and moved by truck if needed
- Prepared for remote support to reduce down time
- Closed cell for zero environmental impact in the workshop keeping sound, light and fumes away from the employees



Robot
KUKA



Welding plant
Kemppi A7



Materials
Steel, aluminum, stainless steel



Dimensioner
Width 2,200 mm, length 3,960 mm,
height 2,320 mm



Solution
The solution is delivered assembled and ready to use



GIBOTECH^{AS}
GiboSmartSolutions

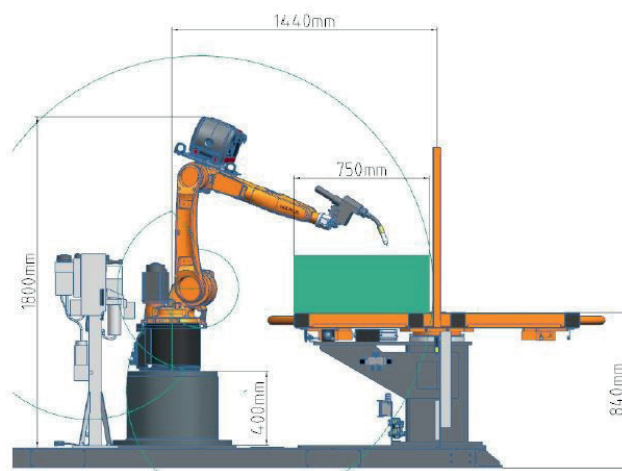
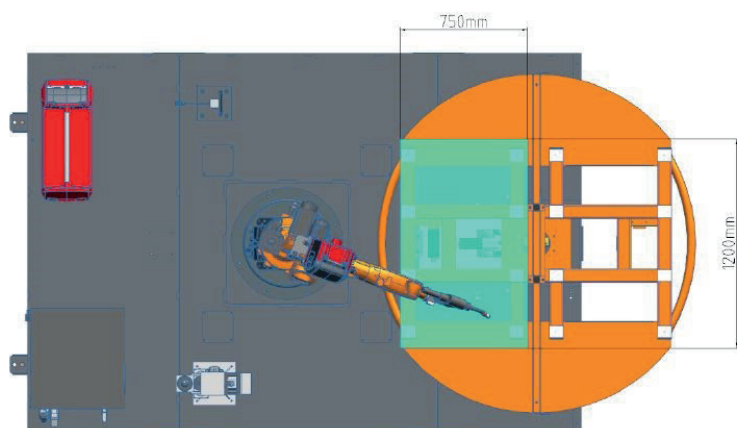

INCLUDED

- 1x completely closed welding cell on frame
 - 2x doors
 - Windows with welding glass
 - Extraction in the ceiling
 - Truck hangers
- 1x KR CYBERTECH nano KR 10 R1420 incl. controller and teach pendant
- 1x Gas-cooled Kemppi A7 350A power source
 - Wirefeeder
 - 5 meter welding gun
- Integrated software for steel, aluminum and stainless steel
- Abicor Binzel cleaning station
 - Mechanical cleaning
 - Spray
 - Wire cutting and TCP reference
- 1x manual turntable, payload 250kg, range 750x1200mm
- Software
 - KUKA WebHMI
 - KUKA ArcTech_Advanced
 - KUKA TraccTCP
- Installation and commissioning at the customer's premises
- Complete documentation package incl. CE documentation
- Robot and welding course for operators

FUNCTIONALITY

GiboWeld Compact is a compact welding solution for MIG/MAG welding of small parts in small or medium series. Welding can be performed in black steel, aluminum and stainless steel. With synergic or pulse ME arc. Despite the compact size of the cell it has a working area of 750 x 1,200 mm.

The cell is particularly suitable for creating the first experiences of automated welding in the transition from manual welding. It is easy to install the cell in the production as it arrives as a finished package with all equipment configured.

After the robot course and welding course, the operator is ready to develop new welding programs for the cell.

GiboWeld has the latest software and can be programmed offline from a PC during the welding process. This saves time and increases productivity compared to manual welding.

The GiboWeld Compact has a smart turntable with two workstations allowing you to prepare new items while the cell is welding. This ensures an efficient production flow with maximum arc time.

GiboWeld is CE approved and designed to protect the environment from welding lights, noise and welding fumes.